

ML Series-REV. D* 2"-12"

Iron Butterfly Valve

200 psi Non-Shock WOG

U Series With Undercut Disc Available @ 50 psi

Bi-Directional Dead End Service to 200 psi Max

BUNA & EPDM Only. All others 150 psi Uni-Directional

Specifications: API-609 MSS SP-67 Type 1



ABS Type Approved; Cat. A
CFR-46

MATERIALS LIST

ITEM	PART	MATERIALS
1	BODY	CAST IRON ASTM A126 CL. B
		CAST IRON EPOXY COATED
		DUCTILE IRON ASTM A536
		DUCTILE IRON-EPOXY COATED
2	DISC	DUCTILE IRON-NYLON COATED
		NP DUCTILE IRON ASTM A536
		ALUMINUM BRONZE ASTM B148
		STAINLESS STEEL ASTM A351 CF8M
		NYLON COATED DUCTILE IRON
		EPOXY COATED DUCTILE IRON
3	BOTTOM STEM	STAINLESS STEEL TYPE 416
		STAINLESS STEEL TYPE 316 (2)
4	TOP STEM	STAINLESS STEEL TYPE 416
		STAINLESS STEEL TYPE 316 (2)
5	TOP BEARING	REINFORCED NYLON
6	SEAL	EPDM, BUNA, VITON (1)
7	LINER	BUNA
		EPDM
		VITON
		HYPALON
		NEOPRENE BLACK-FDA
		NEOPRENE WHITE-FDA
		TEFLON OVER BUNA (150# WOG)
8	ROLL PIN	STAINLESS STEEL
9	STEM SEAL	EPDM, BUNA, VITON (1)
10	LOWER BEARING	REINFORCED NYLON
11	OPERATOR	LEVER HANDLE
		EPOXY COATED LEVER HANDLE
		GEAR OPERATOR
		GEAR OPERATOR WITH MEMORY STOP
		GEAR OPERATOR WITH LOCK
		ACTUATOR-AIR/AIR
		ACTUATOR-AIR/SPRING
		ACTUATOR-ELECTRIC
12	RETAINING RING	1066 SPRING STEEL (65Mn)

(1) - VITON O-RINGS ARE USED WITH HYPALON, NEOPRENE, AND TEFLON LINERS.

(2) 316 STEM USED WITH CF8M DISC

** EPDM AND BUNA LINER ONLY

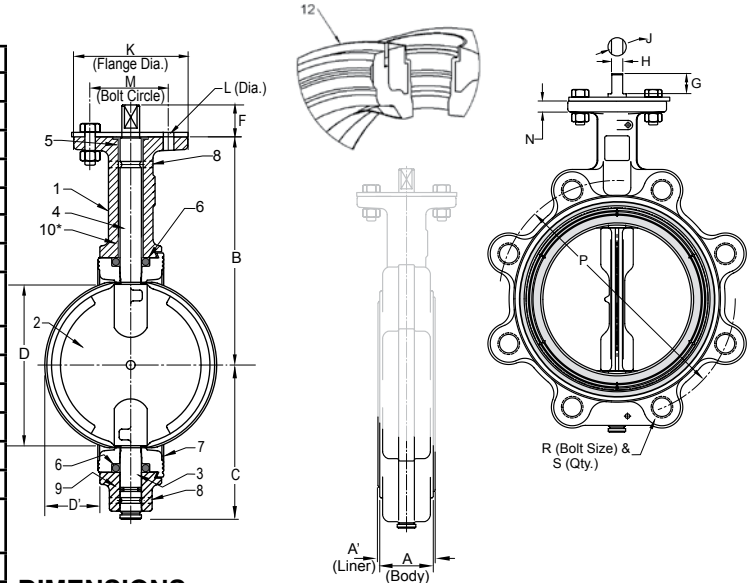

DIMENSIONS

	INCHES DN	VALVE SIZE									
		2	2-1/2	3	4	5	6	8	10	12	
A (Body)	INCHES	1.69	1.81	1.81	2.07	2.19	2.19	2.38	2.69	3.06	
	mm	43	46	46	52	55	55	60	68	78	
A ¹ (Liner)	INCHES	1.82	1.94	1.94	2.20	2.32	2.32	2.51	2.82	3.21	
	mm	46	49	49	55	58	58	63	71	82	
B	INCHES	5.50	6.00	6.25	7.00	7.53	8.00	9.38	10.56	12.06	
	mm	139	152	158	177	191	203	238	268	306	
C	INCHES	3.06	3.31	3.75	4.25	4.94	5.56	5.56	7.88	9.25	
	mm	77	84	95	108	125	141	166	200	235	
D (Chord Dia)	INCHES	1.49	2.01	2.64	3.67	4.71	5.66	7.72	9.70	11.68	
	mm	37	51	67	93	119	143	196	246	296	
D ¹ (Intrusion)	INCHES	0.28	0.44	0.69	1.06	1.50	1.94	2.84	3.69	4.50	
	mm	7	11	17	27	38	49	72	93	114	
F	INCHES	1.13	1.13	1.13	1.13	1.13	1.13	1.50	1.50	1.50	
	mm	28	28	28	28	28	28	38	38	38	
G	INCHES	0.81	0.81	0.81	0.81	0.81	0.81	1.06	1.06	1.06	
	mm	20	20	20	20	20	20	27	27	27	
H	INCHES	0.35	0.35	0.35	0.40	0.40	0.44	0.53	0.71	0.71	
	mm	8	8	8	10	10	11	13	18	18	
J	INCHES	0.50	0.50	0.50	0.56	0.56	0.62	0.75	1.00	1.00	
	mm	12	12	12	14	14	14	19	25	25	
K	INCHES	4	4	4	4	4	4	6	6	6	
	mm	101.6	101.6	101.6	101.6	101.6	101.6	152.4	152.4	152.4	
L (Dia)	INCHES	0.44	0.44	0.44	0.44	0.44	0.44	0.56	0.56	0.56	
	mm	11	11	11	11	11	11	14	14	14	
M	INCHES	3.25	3.25	3.25	3.25	3.25	3.25	5.00	5.00	5.00	
	mm	82	82	82	82	82	82	127	127	127	
N	INCHES	0.44	0.44	0.44	0.44	0.44	0.44	0.50	0.50	0.50	
	mm	11	11	11	11	11	11	12	12	12	
P	INCHES	4.75	5.50	6.00	7.50	8.50	9.50	11.75	14.25	17.00	
	mm	120	139	152	190	215	241	298	362	431	
R	INCHES	5/8-11	5/8-11	5/8-11	5/8-11	3/4-10	3/4-10	3/4-10	7/8-9	7/8-9	
	mm	15.875	15.875	15.875	15.875	19.05	19.05	19.05	19.05	19.05	
S	INCHES	4	4	4	8	8	8	8	12	12	
	mm	101.6	101.6	101.6	203.2	203.2	203.2	203.2	304.8	304.8	

***Note:** The wetted surface of this product (In any material combination.) contacted by consumable water contains less than one quarter of one percent (.25%) of lead by weight.

***Recommend Aluminum Bronze Disc in Water Service.

The information presented on this sheet is correct at time of publication. Milwaukee Valve reserves the right to change design and/or materials without notice. For our Installation, Operation and Maintenance Manual and the most current product information go to www.milwaukeevalve.com.

⚠ State of California Prop 65 **WARNING:** Cancer and Reproductive Harm. For more information visit www.p65warnings.ca.gov.



M**L****2****3****4****V****A**

VALVE SERIES	BODY STYLE	OPERATOR	BODY MATERIAL	DISC MATERIAL	LINER MATERIAL	SPECIAL OPTIONS
H - H SERIES (250 PSI)	L - LUG BODY	1 - VALVE ONLY	2 - CAST IRON*	2 - NICKEL PLATED DUCTILE IRON	B - BUNA-N	S - 316 STEM W/AB OR NP DISC
M - M SERIES	W - WAFER BODY	2 - LEVER HANDLE	3 - DUCTILE IRON	3 - ALUMINUM/BRONZE	E - EPDM	A - EPOXY COATED BODY
O - O SERIES		3 - GEAR OPERATOR		4 - CF8M(316) STAINLESS STEEL	H - HYPALON	AD - ASSEMBLE DRY-NO
U - U SERIES (75 PSI)		5 - GEAR W/MEMORY STOP	*MILWAUKEE VALVE	7 - NYLON COATED DUCTILE IRON	NB - FDA BLACK NEOPRENE	
		9 - GEAR WITH LOCK	RESERVES THE RIGHT TO	8 - EPOXY COATED DUCTILE IRON	NW - FDA WHITE NEOPRENE	
			UPGRADE THE BODY		T - TEFLON OVER BUNA	
			WITHOUT NOTICE FOR NO		(AVAILABLE W/SS DISC ONLY)	
			ADDITIONAL COST.		V - VITON	
		*PNEUMATIC AND ELECTRIC				
		ACTUATION OPTIONS AVAILABLE				

Rev 7/1/2020

BUTTERFLY FEATURES & OPTIONS

STANDARD FEATURES

HEAVY DUTY DESIGN
 PHENOLIC CARTRIDGE DESIGN
 LOW TORQUE LINER
 BUBBLE TIGHT SHUT OFF
 LOW TORQUE POLYMER BEARING STD
 DEAD END SERVICE (LUG ONLY)
 FIELD REPAIRABLE

EXTENDED NECK BODY
 LOW PROFILE DISC
 BLOWOUT PROOF STEMS
 STAINLESS STEEL STEMS (416)
 BI-DIRECTIONAL SHUT OFF (EXCEPT AS NOTED)
 VACUUM RATINGS TO 29" OF MERCURY

OPERATORS

MANUAL

10 POSITION, PAD LOCKABLE, DUCTILE IRON LEVER HANDLE –STD, EPOXY COATING OPTIONAL.

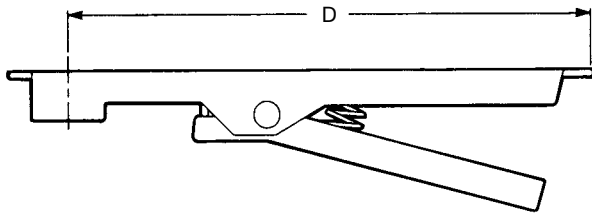

VALVE SIZE	PART NUMBER	T-DIMENSION (inches)
2, 2-1/2, 3	84016-LL	9.50
4, 5	84016-RL	11.00
6	84016-SL	11.00
8	84016-UL	15.00
10, 12	84016-WL	15.00

WEATHER RESISTENT GEAR OPERATOR, CAST IRON, MEMORY STOP AND LOCKING DEVICE OPTIONAL.

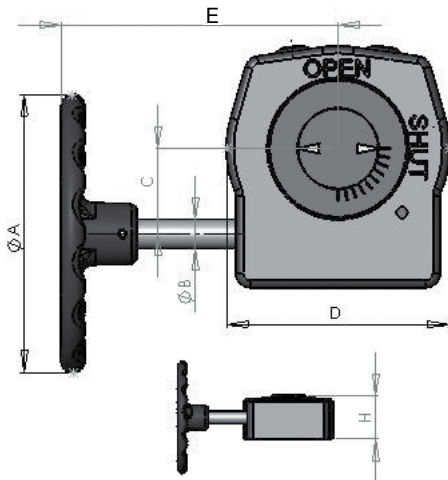

VALVE SIZE	PART NUMBER	GEAR RATIO	ØA	ØB	C	D	E	H
2-3	8115-24N-L	24:1	6.00	0.63	1.80	4.20	8.80	2.30
4-5	8115-24N-R	24:1	6.00	0.63	1.80	4.20	8.80	2.30
6	8115-24N-S	24:1	6.00	0.63	1.80	4.20	8.80	2.30
8	8115-30N-U	30:1	9.00	0.75	2.60	6.03	8.50	3.23
10-12	8115-30N-W	30:1	9.00	0.75	2.60	6.03	8.50	3.23
14-16	8115-48N-16	50:1	12.00	0.75	3.10	6.97	13.40	3.46
18-20	8115-65N-20	80:1	12.00	1.00	4.93	10.30	12.60	4.63
24	8115-78N-24	120:1	16.00	1.00	4.93	10.30	12.60	6.00

ACTUATORS

PNEUMATIC OPERATORS
 DOUBLE ACTING OPERATORS
 SPRING-RETURN ACTUATORS
 SOLENOID VALVES
 ACTUATOR BRACKETS
 LIMIT SWITCHES
 VALVE POSITIONERS

120 VOLT AC AND DC VOLTAGES
 NEMA 4 AND 7 HOUSING
 4-20 mA DC VALVE POSITIONERS
 ACTUATOR BRACKETS
 EXTRA LIMIT SWITCHES
 ELECTRIC ACTUATORS

The information presented on this sheet is correct at time of publication. Milwaukee Valve reserves the right to change design and/or materials without notice. For our Installation, Operation and Maintenance Manual and the most current product information go to www.milwaukeevalve.com.
 ⚠ State of California Prop 65 **WARNING:** Cancer and Reproductive Harm. For more information visit www.p65warnings.ca.gov.



OPTIONS & ACCESSORIES

MEMORY STOP

The "MS" Memory Stop provides an adjustable stop when the valve is used in a balancing application. The Memory Stop can be set to any preset opening point.

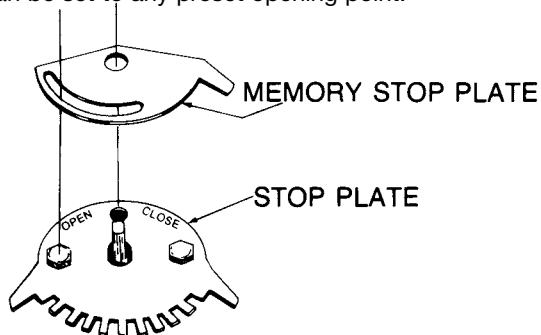

STEM EXTENSION

Provides means of operation at a required distance away from the valve body. Manual or automatic, actuators are easily adapted to mounting flange on the extension. To order, specify distance from valve mounting-flange to base of operator. (Please note: Butterball® extension stems are available in 1-1/4" and 2-1/4" sizes only.)

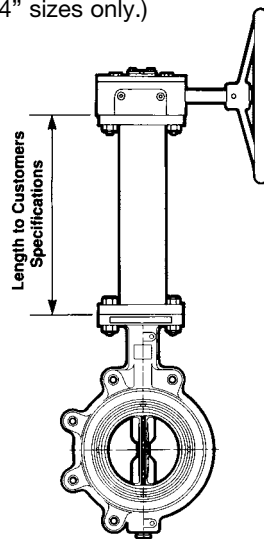

CHAINWHEEL

The chain wheel provides for remote operation of the valve in high, normally out-of-reach locations. Attaches to the gear operator easily for quick valve open/close response. Sprocket rim is aluminum; chain is steel. Specify the handwheel diameter ("A" dimension) and chain length. Chainwheel sold separately.

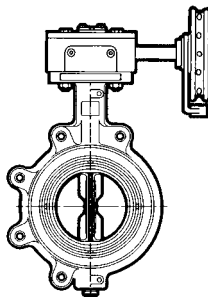

Butterfly Height With Lever or Gear Operator

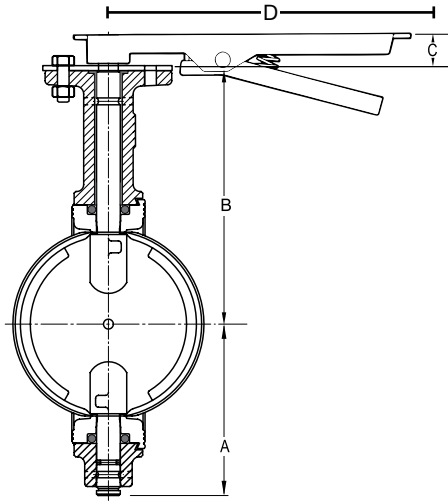

2"-12"

Butterfly with Lever Handle						
Size		A	B	C	D	Height
2"	INCHES	3.06	5.50	1.13	9.50	19.19
2 1/2"	INCHES	3.31	6.00	1.13	9.50	19.94
3"	INCHES	3.75	6.25	1.13	9.50	20.63
4"	INCHES	4.25	7.00	1.13	11.00	23.38
5"	INCHES	4.94	7.53	1.13	11.00	13.60
6"	INCHES	5.56	8.00	1.13	11.00	14.69
8"	INCHES	5.56	9.38	1.50	15.00	31.44
10"	INCHES	7.88	10.56	1.50	15.00	34.94
12"	INCHES	9.25	12.06	1.50	15.00	37.81

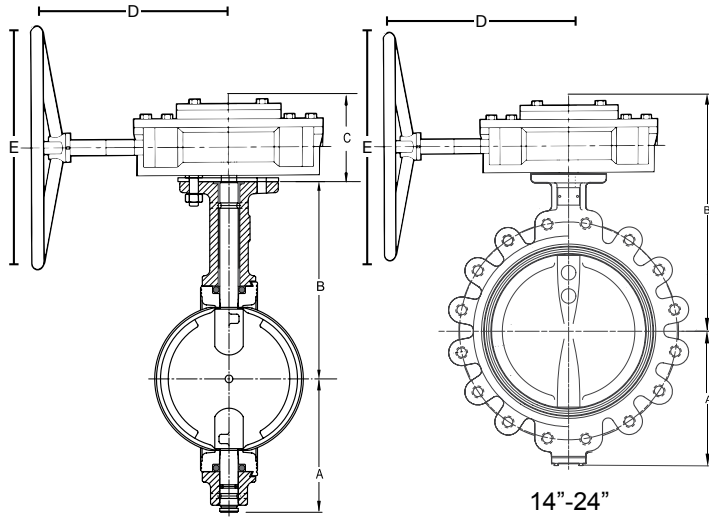

2"-12"

14"-24"

Butterfly with Gear Operator							
Size		A	B	C	D	E	Height
2"	INCHES	3.06	5.50	2.30	8.80	6.00	10.86
2 1/2"	INCHES	3.31	6.00	2.30	8.80	6.00	11.61
3"	INCHES	3.75	6.25	2.30	8.80	6.00	12.30
4"	INCHES	4.25	7.00	2.30	8.80	6.00	13.55
5"	INCHES	4.94	7.53	2.30	8.80	6.00	14.77
6"	INCHES	5.56	8.00	2.30	8.80	6.00	15.86
8"	INCHES	5.56	9.38	3.23	8.50	9.00	18.17
10"	INCHES	7.88	10.56	3.23	8.50	9.00	21.67
12"	INCHES	9.25	12.06	3.23	8.50	9.00	24.54
14"	INCHES	11.56	17.25	-	13.40	12.00	28.81
16"	INCHES	12.69	18.75	-	13.40	12.00	31.44
18"	INCHES	13.63	19.63	-	12.60	12.00	33.26
20"	INCHES	15.13	20.88	-	12.60	12.00	36.01
24"	INCHES	18.06	25.00	-	12.60	16.00	43.06

Note: 30"-48" Please see specification sheet.

The information presented on this sheet is correct at time of publication. Milwaukee Valve reserves the right to change design and/or materials without notice. For our Installation, Operation and Maintenance Manual and the most current product information go to www.milwaukeevalve.com.
 ⚠ State of California Prop 65 **WARNING:** Cancer and Reproductive Harm. For more information visit www.p65warnings.ca.gov.

