

# ML Series\* 14"- 24"

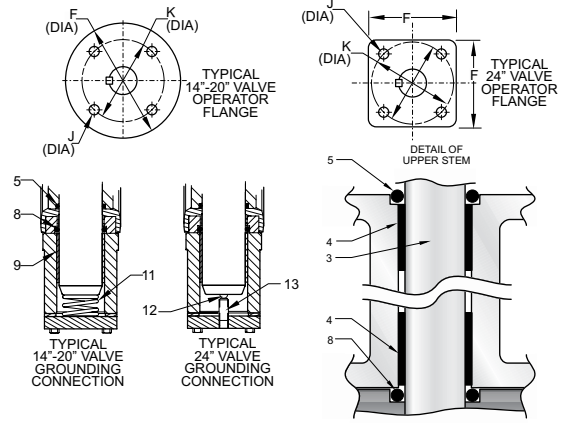

ABS Type Approved; Cat. A  
CFR-46

**Iron Butterfly Valve**  
**150 psi Non-Shock WOG**  
**U Series With Undercut Disc Available @ 50 psi**  
**For Dead End Service use ML Series**  
**Specifications: MSS SP-67 Type 1**

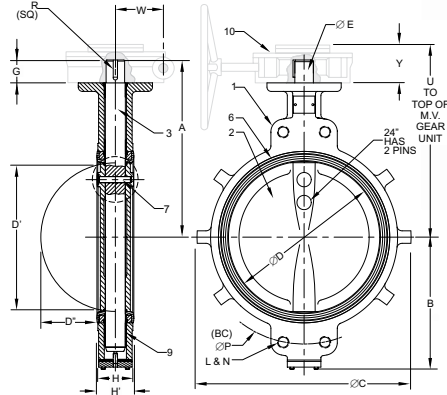

## MATERIALS LIST

ITEM	PART	MATERIALS
1	BODY	CAST IRON ASTM A126 CL. B
		CAST IRON EPOXY COATED
		DUCTILE IRON ASTM A536
		DUCTILE IRON-EPOXY COATED
2	DISC	NP DUCTILE IRON ASTM A536
		ALUMINUM BRONZE ASTM B 148 **
		STAINLESS STEEL TYPE 316
3	STEM	STAINLESS STEEL TYPE 416
		STAINLESS STEEL TYPE 316
4	TOP BEARING	REINFORCED NYLON
5	STEM O-RING	EPDM, BUNA, VITON (1)
6	LINER	BUNA
		EPDM
		VITON
		HYPALON
7	STEM PIN	ANSI 4140 OR AISI 6150
8	LINER O-RING	EPDM, BUNA, VITON (1)
9	LOWER BEARING	REINFORCED NYLON
10	OPERATOR	GEAR OPERATOR
		GEAR OPERATOR WITH MEMORY STOP
		GEAR OPERATOR WITH LOCK
		ACTUATOR-AIR/AIR (2)
		ACTUATOR-AIR/SRING (2)
11	GROUNDING SPRING	STAINLESS STEEL TYPE 302
		14"-20"
12	GROUNDING BALL	AISI-1022
13	TENSION SCREW	AISI-1020

- (1) - O-Ring Matches Liner; Viton Default if no Direct Match.
- (2) - Consult Automation Department

**\*Note:** The wetted surface of this product (In any material combination.) contacted by consumable water contains less than one quarter of one percent (.25%) of lead by weight.

\*\*Recommend Aluminum Bronze Disc in Water Service.

## DIMENSIONS

	INCHES	VALVE SIZE				
		14	16	18	20	24
A	DN	352	406	457	508	610
	INCHES	15.50	16.75	18.50	19.75	22.43
B	INCHES	11.56	12.69	13.63	15.13	18.06
	mm	298	322	346	384	458
C	INCHES	21.00	23.50	25.00	27.50	32.10
	mm	533	596	635	698	815
D	INCHES	13.25	15.25	17.24	19.24	23.25
	mm	336	387	438	489	591
D <sup>1</sup> (Chord Dia.)	INCHES	12.94	14.77	16.70	18.64	22.49
	mm	329	375	424	474	571
D <sup>11</sup> (Intrusion)	INCHES	5.06	5.59	6.34	7.09	8.55
	mm	128	142	161	180	217
E	INCHES	1.63	1.63	2.13	2.13	2.13
	mm	41	41	54	54	54
F	INCHES	6.50	6.50	9.50	9.50	7.50
	mm	165	165	241	241	190
G	INCHES	2.00	2.00	3.00	3.00	3.06
	mm	50	50	76	76	77
H (Body)	INCHES	3.06	4.00	4.50	5.00	6.06
	mm	77	101	114	127	153
H <sup>1</sup> (Liner)	INCHES	3.19	4.13	4.63	5.13	6.19
	mm	81	104	117	130	157
J	INCHES	0.69	0.69	0.81	0.81	0.81
	mm	17	17	20	20	20
K	INCHES	5.25	5.25	7.50	7.50	7.50
	mm	133	133	190	190	190
L	No. of Holes	4	4	4	4	4
M	Flange Bolt Size	1-8	1-8	1 1/8-7	1 1/8-7	1 1/4-7
		INCHES	1 1/8	1 1/8	1 1/4	1 1/4
N (Hole Dia.)	mm	29	29	32	32	35
	INCHES	18.75	21.25	22.75	25.00	29.50
P	mm	476	540	577	635	749
	INCHES	0.38	0.38	0.50	0.50	0.50
R (Key Size)	mm	9	9	12	12	12
	INCHES	17.25	18.75	19.63	20.88	25.00
U	mm	438	476	458	530	635
	INCHES	3.13	3.13	4.50	4.50	4.63
W	mm	79	79	114	114	117

The information presented on this sheet is correct at time of publication. Milwaukee Valve reserves the right to change design and/or materials without notice. For our Installation, Operation and Maintenance Manual and the most current product information go to [www.milwaukeevalve.com](http://www.milwaukeevalve.com).  
 ⚠ State of California Prop 65 **WARNING:** Cancer and Reproductive Harm. For more information visit [www.p65warnings.ca.gov](http://www.p65warnings.ca.gov).

