



MASON INDUSTRIES, Inc.

MERCER RUBBER Co.

350 Rabro Drive, Hauppauge, NY 11788
Mason- 631/348-0282 • Info@Mason-Ind.com
Mercer- 631/582-1524 • Info@Mercer-Rubber.com
FAX 631/348-0279



JOB NAME
CUSTOMER
CUSTOMER P.O.
MASON M.
DWG No.

MN

SS BRAIDED HOSE with CARBON STEEL THREADED NIPPLES

Vacuum rating varies with size and application. Consult factory on all vacuum applications.

CARBON STEEL SCHEDULE 40 NPT NIPPLES or as checked below

- Metric Nipples
British Standard Nipples

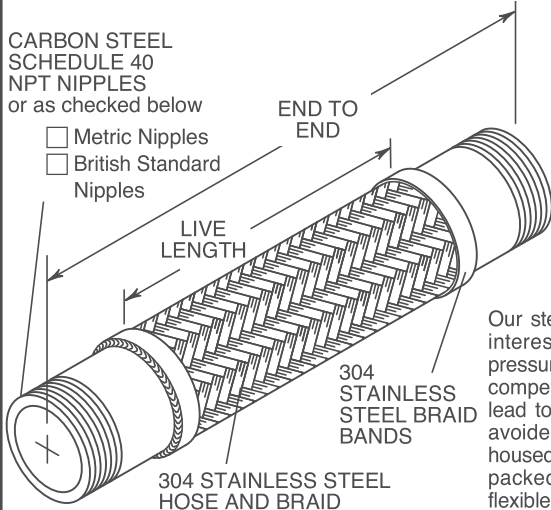

Our steam service ratings are very low in the interest of safety although our 70°F (21°C) pressure ratings are as high or higher than our competitors. All locations where failure could lead to personal injury or suffocation must be avoided. In dangerous locations we suggest housed expansion joints, solid loops, ball joints, packed devices etc. rather than thin walled flexible products regardless of manufacturer.

RATED PRESSURES @ ELEVATED TEMPERATURES (psi) (kg/cm²)

Table with columns: Hose Size (in) (mm), 250°F (121°C) Factor 0.92, 350°F (176°C) Factor 0.86, 450°F (232°C) Factor 0.81. Rows include sizes from 1/2 to 4 inches.

SATURATED STEAM RECOMMENDED PRESSURE LIMITS

Table with columns: Size (in) (mm), Max Gauge (psi) (kg/cm²), Temp Reference (°F) (°C). Rows include sizes from 1/2 to 4 inches.

Consult factory with full location description as well as service conditions for higher pressure or temperature applications.

304 SS can be used up to 850°F (454°C) in applications such as engine exhaust.

When using MN products in copper or brass water or steam systems, dielectric unions must be used on each end to prevent leakage from galvanic action.

MN DIMENSIONS AND PRESSURE RATINGS (American Units)

Table with columns: Type, Pipe Size & End to End (in), Live Length (in), Corrugations per foot, Maximum Permanent Lateral Offset (in), Rated Pressure @70°F (psi). Rows include various sizes from 1/2 to 4 inches.

MN DIMENSIONS AND PRESSURE RATINGS (Metric Units)

Table with columns: Type, Pipe Size & End to End (mm), Live Length (mm), Corrugations per meter, Maximum Permanent Lateral Offset (mm), Rated Pressure @21°C (kg/cm²). Rows include various sizes from 15x305 to 100x914 mm.

End to End Tolerance: minus 1% plus 3%. Minimum Burst is four times the Rated Pressure. Safety factor of 4. Lateral Offset one side of centerline and normal machinery vibration. If intermittent in both directions, reduce by 50%.

Table with columns: QTY, SIZE, TAG

Table with columns: QTY, SIZE, TAG