



MASON INDUSTRIES, Inc.

MERCER RUBBER Co.

350 Rabro Drive, Hauppauge, NY 11788
Mason- 631/348-0282 • Info@Mason-Ind.com
Mercer- 631/582-1524 • Info@Mercer-Rubber.com
FAX 631/348-0279



JOB NAME
CUSTOMER
CUSTOMER P.O.
MASON M.
DWG No.

GWNF

SS BRAIDED HOSE
with CARBON
STEEL GROOVED
WELD NIPPLE and
FIXED FLANGE

Vacuum rating varies with size
and application. Consult factory
on all vacuum applications.

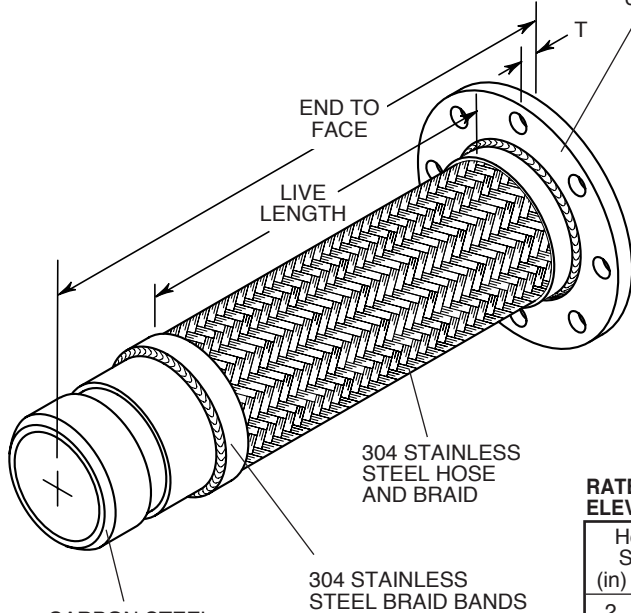

CARBON STEEL
SCHEDULE 40
NIPPLE grooved
for couplings
and beveled for
welding alternate

304 STAINLESS
STEEL BRAID BANDS

304 STAINLESS
STEEL HOSE
AND BRAID

CARBON STEEL
RAISED FACE
FIXED FLANGE
150 lb ASA Drilling
or as checked below

- ASA-300 DIN 10
DIN 16 DIN 25

CARBON STEEL PLATE FLANGE THICKNESS

Table with 3 columns: Pipe Size (in/mm), Flange Thickness T (in/mm). Rows for pipe sizes 2-4, 5-6, 8-12.

Our steam service ratings are very low in the interest of safety although our 70°F (21°C) pressure ratings are as high or higher than our competitors.

Consult factory with full location description as well as service conditions for higher pressure or temperature applications.

304 SS can be used up to 850°F (454°C) in applications such as engine exhaust.

When using GWNF products in copper or brass water or steam systems, a dielectric flange must be used on the flanged end and a dielectric coupling on the nipple end to prevent leakage from galvanic action.

RATED PRESSURES @
ELEVATED TEMPERATURES (psi) (kg/cm²)

Table with 4 columns: Hose Size (in/mm), 250°F (121°C), 350°F (176°C), 450°F (232°C). Rows for hose sizes 2-12.

SATURATED STEAM RECOMMENDED
PRESSURE LIMITS

Table with 3 columns: Size (in/mm), Max Gauge (psi/kg/cm²), Temp Reference (°F/°C). Rows for sizes 2-12.

GWNF DIMENSIONS AND PRESSURE RATINGS (American Units)

Table with 5 columns: Type, Pipe Size & End to Face (in), Live Length (in), Corrugations per foot, Maximum Permanent Lateral Offset (in), Rated Pressure @70°F (psi). Rows for various GWNF types.

GWNF DIMENSIONS AND PRESSURE RATINGS (Metric Units)

Table with 5 columns: Type, Pipe Size & End to Face (mm), Live Length (mm), Corrugations per meter, Maximum Permanent Lateral Offset (mm), Rated Pressure @21°C (kg/cm²). Rows for various GWNF types.

End to Face Tolerance: minus 1% plus 3%. Minimum Burst is four times the Rated Pressure. Safety factor of 4.
Lateral Offset one side of centerline and normal machinery vibration. If intermittent in both directions, reduce by 50%.
Size 12" (300mm) has double braid.

Table with 3 columns: QTY, SIZE, TAG. Empty rows for order entry.

Table with 3 columns: QTY, SIZE, TAG. Empty rows for order entry.