



MASON INDUSTRIES, Inc.

MERCER RUBBER Co.

350 Rabro Drive, Hauppauge, NY 11788
Mason- 631/348-0282 • Info@Mason-Ind.com
Mercer- 631/582-1524 • Info@Mercer-Rubber.com
FAX 631/348-0279



JOB NAME
CUSTOMER
CUSTOMER P.O.
MASON M.
DWG No.

CSAMN

SS BRAIDED HOSE with CARBON STEEL THREADED NIPPLES

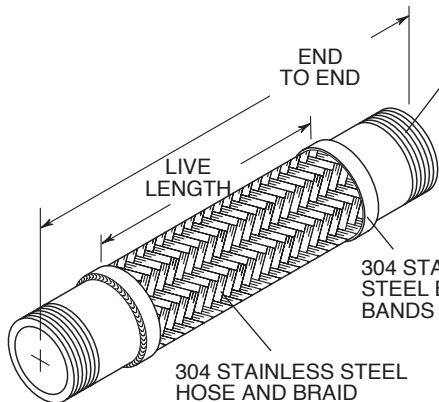

CARBON STEEL SCHEDULE 40 NPT NIPPLES or as checked below
CSAFU- Fe. NPT Unions
CSAFS- Fe. Swivels
CSAMNFU- Nipple x Fe. Union
CSAMNFS- Nipple x Fe. Swivel

FU- Female NPT Union

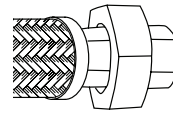

These assemblies have been "CSA International" approved for use on gas pipelines. "CSA International" is the current certification agency for gas industry products, assuming the authority formerly associated with the American Gas Association (AGA).

FS- Female JIC/SAE Flared Swivel

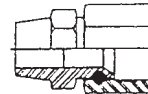

Our Certification Report is #230720-1764990. This Certification meets all requirements of ANSI/UL #536 2003 Standards for Flexible Metal Hose.

OPTIONAL FITTINGS MATERIAL as checked below
Stainless Steel

CSAMN DIMENSIONS AND PRESSURE RATINGS (American Units)

Table with columns: Pipe Size (in), End to End (in), Live Length (in), Corrugations per foot, Maximum Permanent Lateral Offset (in), Rated Pressure @70°F (psi), Min Pressure Burst (psi), Safety Factor. Rows include sizes from 1/2 to 4 inches.

CSAMN DIMENSIONS AND PRESSURE RATINGS (Metric Units)

Table with columns: Pipe Size (mm), End to End (mm), Live Length (mm), Corrugations per meter, Maximum Permanent Lateral Offset (mm), Rated Pressure @21°C (kg/cm²), Min Pressure Burst (kg/cm²), Safety Factor. Rows include sizes from 15 to 100 mm.

End to End Tolerance: minus 1% plus 3%. Lateral Offset one side of centerline and normal machinery vibration. If intermittent in both directions, reduce by 50%.

Table with columns: QTY, SIZE, TAG

Table with columns: QTY, SIZE, TAG