



MASON INDUSTRIES, Inc.

MERCER RUBBER Co.

350 Rabro Drive, Hauppauge, NY 11788
 Mason- 631/348-0282 • Info@Mason-Ind.com
 Mercer- 631/582-1524 • Info@Mercer-Rubber.com
 FAX 631/348-0279



JOB NAME _____
 CUSTOMER _____
 CUSTOMER P.O. _____
 MASON M. _____
 DWG No. _____

FFLSS

304 SS BRAIDED
 HOSE with 304
 STAINLESS STEEL
 FIXED & FLOATING
 FLANGES

**Vacuum rating varies with size and application.
 Consult factory on all vacuum applications.**

304 STAINLESS
 STEEL FLOATING
 FLANGE 150 lb
 ASA Drilling or as
 checked below

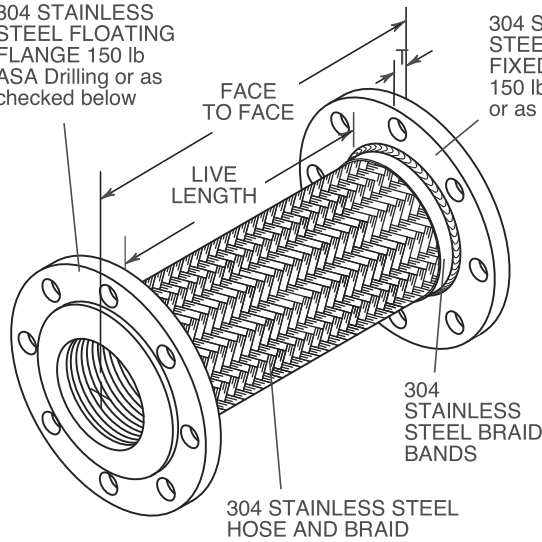

304 STAINLESS
 STEEL RAISED FACE
 FIXED FLANGE
 150 lb ASA Drilling
 or as checked below

- ASA-300
- DIN 10
- DIN 16
- DIN 25

When using FFLSS products in copper or brass water or steam systems, dielectric flanges must be used on each end to prevent leakage from galvanic action.

STAINLESS STEEL PLATE FLANGE THICKNESS

Pipe Size (in)	Flange Thickness T (in)	Flange Thickness T (mm)
2 thru 4	5/8	16
5 thru 6	3/4	19
8 thru 12	1	25

RATED PRESSURES @ ELEVATED TEMPERATURES (psi) (kg/cm²)

Hose Size (in) (mm)	250°F 121°C Factor 0.92	350°F 176°C Factor 0.86	450°F 232°C Factor 0.81
2 50	330 23	310 21	290 20
2 1/2 65	270 19	250 17	235 16
3 80	260 18	240 16	230 16
4 100	210 15	200 14	190 13
5 125	190 13	180 12	170 11
6 150	190 13	180 12	170 11
8 200	190 13	180 12	170 11
10 250	160 11	150 10	140 9
12 300	160 11	150 10	140 9

SATURATED STEAM RECOMMENDED PRESSURE LIMITS

Size (in) (mm)	Max Gauge (psi) (kg/cm ²)	Temp Reference (F) (°C)
2 50	150 11	362 183
2 1/2 65	125 9	355 179
3 80	125 9	355 179
4 100	125 9	355 179
5 125	100 7	337 169
6 150	100 7	337 169
8 200	75 5	320 160
10 250	60 4	307 153
12 300	60 4	307 153

Our steam service ratings are very low in the interest of safety although our 70°F (21°C) pressure ratings are as high or higher than our competitors. All locations where failure could lead to personal injury or suffocation must be avoided. In dangerous locations we suggest housed expansion joints, solid loops, ball joints, packed devices etc. rather than thin walled flexible products regardless of manufacturer.

Consult factory with full location description as well as service conditions for higher pressure or temperature applications.

304 SS can be used up to 850°F (454°C) in applications such as engine exhaust.

FFLSS DIMENSIONS AND PRESSURE RATINGS (American Units)

Type	Pipe Size & Face to Face (in)	Live Length (in)	Corrugations per foot	Maximum Permanent Lateral Offset (in)	Rated Pressure @70°F (psi)
FFLSS	2 X 12	93/4	58	11/8	360
FFLSS	2 1/2 X 12	9	48	1	290
FFLSS	3 X 12	9	46	7/8	280
FFLSS	4 X 12	9	32	3/4	225
FFLSS	4 X 18	15	32	11/2	225
FFLSS	5 X 18	143/4	29	11/8	200
FFLSS	6 X 18	143/4	25	1	200
FFLSS	8 X 24	197/8	23	11/2	200
FFLSS	10 X 24	197/8	21	11/4	170
FFLSS	12 X 24	197/8	20	1	170

FFLSS DIMENSIONS AND PRESSURE RATINGS (Metric Units)

Type	Pipe Size & Face to Face (mm)	Live Length (mm)	Corrugations per meter	Maximum Permanent Lateral Offset (mm)	Rated Pressure @21°C (kg/cm ²)
FFLSS	50 X 305	248	190	29	25
FFLSS	65 X 305	229	157	25	20
FFLSS	80 X 305	229	151	22	19
FFLSS	100 X 305	229	105	19	15
FFLSS	100 X 457	381	105	38	15
FFLSS	125 X 457	375	95	29	14
FFLSS	150 X 457	375	82	25	14
FFLSS	200 X 610	521	75	38	14
FFLSS	250 X 610	521	69	32	11
FFLSS	300 X 610	521	66	25	11

Face to Face Tolerance: minus 1% plus 3%. Minimum Burst is four times the Rated Pressure. Safety factor of 4.
 Lateral Offset one side of centerline and normal machinery vibration. If intermittent in both directions, reduce by 50%.
 Size 12" (300mm) has double braid.

QTY	SIZE	TAG

QTY	SIZE	TAG