



**MASON INDUSTRIES, Inc.**  
**MERCER RUBBER Co.**

350 Rabro Drive, Hauppauge, NY 11788  
 Mason- 631/348-0282 • Info@Mason-Ind.com  
 Mercer- 631/582-1524 • Info@Mercer-Rubber.com  
 FAX 631/348-0279



JOB NAME \_\_\_\_\_  
 CUSTOMER \_\_\_\_\_  
 CUSTOMER P.O. \_\_\_\_\_  
 MASON M. \_\_\_\_\_  
 DWG No. \_\_\_\_\_

**FFL-2B300**

**SS DOUBLE BRAIDED  
 HOSE with CARBON  
 STEEL FIXED &  
 FLOATING FLANGES  
 ASA-300**

**Vacuum rating varies with size and application.  
 Consult factory on all vacuum applications.**

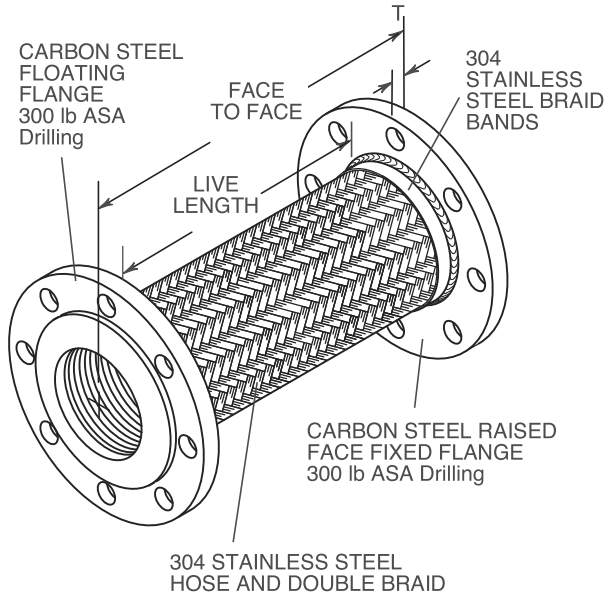

**RATED PRESSURES @ ELEVATED TEMPERATURES (psi) (kg/cm<sup>2</sup>)**

Hose Size (in) (mm)	250°F 121°C		350°F 176°C		450°F 232°C	
	Factor 0.92		Factor 0.86		Factor 0.81	
2 50	460	31	430	29	405	28
2 1/2 65	460	31	430	29	405	28
3 80	345	24	323	22	304	21
4 100	345	24	323	22	304	21
5 125	345	24	323	22	304	21
6 150	345	24	323	22	304	21
8 200	216	15	202	14	190	13
10 250	193	13	181	12	170	11
12 300	156	11	146	10	138	9

**SATURATED STEAM RECOMMENDED PRESSURE LIMITS**

Size (in) (mm)	Max Gauge (psi) (kg/cm <sup>2</sup> )	Temp Reference (F) (°C)
2 50	200 14	388 198
2 1/2 65	150 10	362 183
3 80	150 10	362 183
4 100	150 10	362 183
5 125	125 9	355 179
6 150	125 9	355 179
8 200	90 6	330 166
10 250	75 5	307 153
12 300	60 4	307 153

Our steam service ratings are very low in the interest of safety although our 70°F (21°C) pressure ratings are as high or higher than our competitors. All locations where failure could lead to personal injury or suffocation must be avoided. In dangerous locations we suggest housed expansion joints, solid loops, ball joints, packed devices etc. rather than thin walled flexible products regardless of manufacturer.

Consult factory with full location description as well as service conditions for higher pressure or temperature applications.

304 SS can be used up to 850°F (454°C) in applications such as engine exhaust.

When using FFL-2B300 products in copper or brass water or steam systems, dielectric flanges must be used on each end to prevent leakage from galvanic action.

**CARBON STEEL PLATE FLANGE THICKNESS**

Pipe Size (in)	Flange Thickness T (in) (mm)
2 thru 4 50 thru 100	3/4 19
5 thru 6 125 thru 150	1 25
8 thru 12 200 thru 300	1 1/4 32

Face to Face Tolerance: minus 1% plus 3%. Minimum Burst is four times the Rated Pressure. Safety factor of 4. Lateral Offset one side of centerline and normal machinery vibration. If intermittent in both directions, reduce by 50%.

**FFL-2B300 DIMENSIONS AND PRESSURE RATINGS (American Units)**

Pipe Size & Face to Face (in)	Live Length (in)	Corrugations per foot	Maximum Permanent Lateral Offset (in)	Rated Pressure @70°F (psi)
2 X 12	93/8	58	1	500
2 1/2 X 12	87/8	48	7/8	500
3 X 12	87/8	46	3/4	375
4 X 12	87/8	32	5/8	375
4 X 18	147/8	32	1 1/4	375
5 X 18	141/4	29	1 1/8	375
6 X 18	141/4	25	7/8	375
8 X 24	191/2	23	1 1/4	235
10 X 24	191/2	21	1 1/8	210
12 X 24	191/2	20	7/8	170

**FFL-2B300 DIMENSIONS AND PRESSURE RATINGS (Metric Units)**

Pipe Size & Face to Face (mm)	Live Length (mm)	Corrugations per meter	Maximum Permanent Lateral Offset (mm)	Rated Pressure @21°C (kg/cm <sup>2</sup> )
50 X 305	238	190	25	35
65 X 305	225	157	22	35
80 X 305	225	151	19	26
100 X 305	225	105	16	26
100 X 457	378	105	32	26
125 X 457	362	95	29	26
150 X 457	362	82	22	26
200 X 610	495	75	32	16
250 X 610	495	69	29	14
300 X 610	495	66	22	11

QUANTITY	SIZE	TAG