



MASON INDUSTRIES, Inc.

MERCER RUBBER Co.

350 Rabro Drive, Hauppauge, NY 11788
 Mason- 631/348-0282 • Info@Mason-Ind.com
 Mercer- 631/582-1524 • Info@Mercer-Rubber.com
 FAX 631/348-0279



JOB NAME _____
 CUSTOMER _____
 CUSTOMER P.O. _____
 MASON M. _____
 DWG No. _____

EW50

50 psi FULL VACUUM
 BELLOWS
 EXPANSION
 JOINT with
 WELD ENDS

Full Vacuum Rating- 30" (762mm) Hg

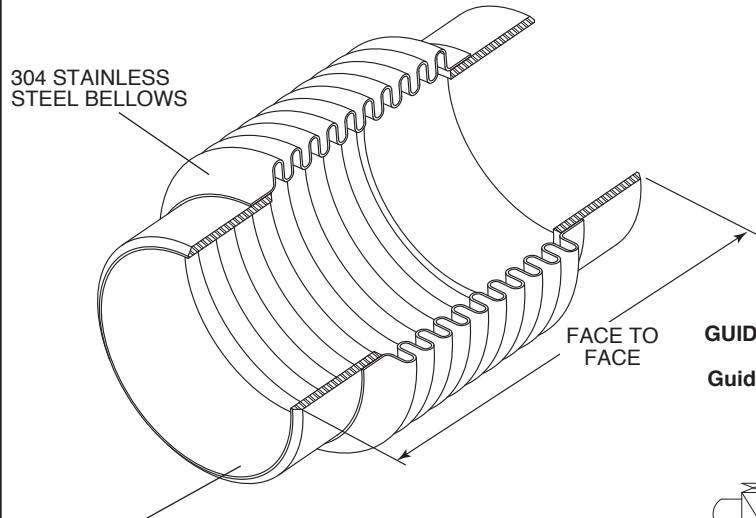

CARBON STEEL
 STANDARD
 WEIGHT
 BEVELED
 WELD ENDS

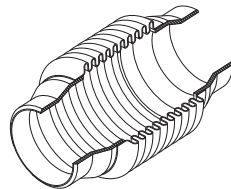

Our 4" design uses 5" stainless bellows between reducers for greater stability.

EW50 RATED PRESSURES @ ELEVATED TEMPERATURES

Temperature (°F)	Temperature (°C)	Rated Pressure (psi)(kg/cm ²)	
200	93	46	3.2
300	149	43	3.0
400	204	39	2.7
500	260	38	2.7
800	427	37	2.6
1000	538	30	2.1
1500	816	13	0.9

GUIDE SPACING – Referencing Pipe Diameter "D"

Guides and Anchors for Joint located near Anchor

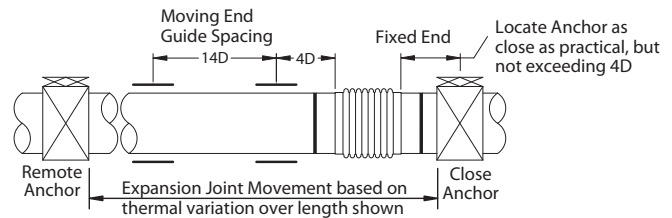

Guides and Anchors for Joint located between Remote Anchors

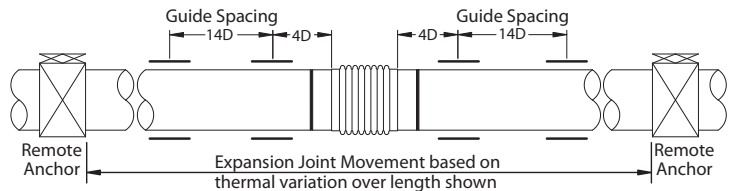

EW50 DIMENSIONS AND PRESSURE RATINGS (American & Metric Units) 2" (50mm) AXIAL MOVEMENT, 1/4" (6mm) LATERAL DEFLECTION

Type & Size	Pipe Size		Face to Face		Axial Spring Rate		Lateral Spring Rate		Thrust ¹ @		Rated Pressure		Ship Wt.	
	(in)	(mm)	(in)	(mm)	(lbs/in)	(kg/cm)	(lbs/in)	(kg/cm)	50 psi (lbs)	3 kg/cm ² (kg)	@70°F (psi)	@21°C (kg/cm ²)	(lbs)	(kg)
EW50-4	4	100	173/4	451	640	115	850	152	1400	635	50	3	14	6
EW50-5	5	125	141/4	362	640	115	850	152	1400	635	50	3	15	7
EW50-6	6	150	151/4	387	890	159	1400	250	1900	862	50	3	16	7
EW50-8	8	200	151/2	394	1130	202	3700	661	3200	1451	50	3	27	13
EW50-10	10	250	153/4	400	1250	223	6400	1143	4800	2177	50	3	35	16
EW50-12	12	300	173/4	451	1360	243	7790	1391	6600	2994	50	3	46	21
EW50-14	14	350	181/2	470	1410	252	9450	1688	8800	3992	50	3	62	38
EW50-16	16	400	19	483	1810	323	18160	3243	11300	5126	50	3	82	37

EW may be used for 2" Expansion or 2" Compression from neutral length or any combined 2" from neutral. i.e. (+ 1 1/2, - 1/2) (+ 1, - 1) (+ 1/4, - 13/4) etc. Total movement should never exceed 2".

¹Lower Thrust Forces in proportion at lower pressures, i.e. 20 psi Force = 20/50 x published Thrust. Anchors must resist Thrust Force plus Spring Force. Spring Force is determined by multiplying the joint Spring Rate by its Thermal Movement (in/mm).

EW's installed in piping systems must be anchored on both sides of the joint. EW's installed in unanchored piping must have control rods. When using EW products in copper or brass water or steam systems, dielectric unions must be used on each end to prevent leakage from galvanic action.

QTY	SIZE	TAG

QTY	SIZE	TAG



MASON INDUSTRIES, Inc.

MERCER RUBBER Co.

350 Rabro Drive, Hauppauge, NY 11788
 Mason- 631/348-0282 • Info@Mason-Ind.com
 Mercer- 631/582-1524 • Info@Mercer-Rubber.com
 FAX 631/348-0279



JOB NAME _____
 CUSTOMER _____
 CUSTOMER P.O. _____
 MASON M. _____
 DWG No. _____

EW250

250 psi FULL
 VACUUM BELLOWS
 EXPANSION
 JOINT with
 WELD ENDS

Full Vacuum Rating- 30" (762mm) Hg

EW250 RATED PRESSURES @ ELEVATED TEMPERATURES

Temperature (°F)	Temperature (°C)	Rated Pressure (psi)(kg/cm ²)	
200	93	227	15.9
250	121	220	15.4
300	149	212	14.9
400	204	195	13.7
500	260	192	13.4
600	316	190	13.3
700	371	185	13.0
800	427	Not Recommended	

304 STAINLESS STEEL BELLOWS

CARBON STEEL STANDARD WEIGHT BEVELED WELD ENDS

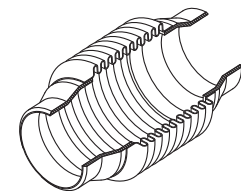
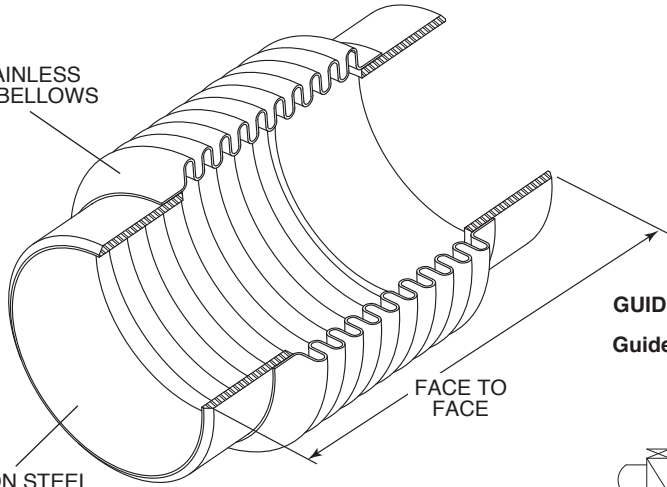

Our 2" - 4" designs use 5" stainless bellows between reducers for greater stability.

GUIDE SPACING - Referencing Pipe Diameter "D"

Guides and Anchors for Joint located near Anchor

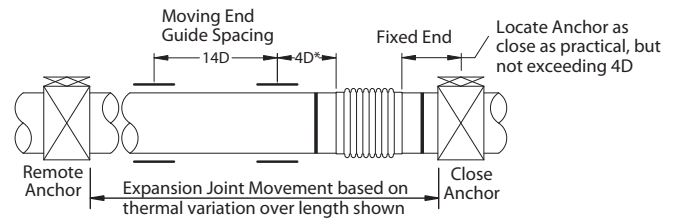

Guides and Anchors for Joint located between Remote Anchors

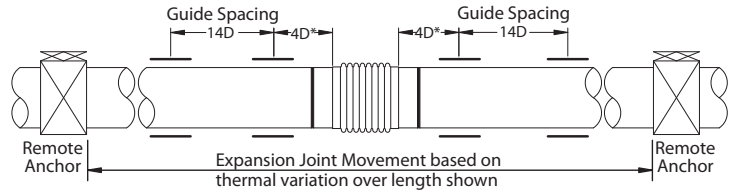

EW250 DIMENSIONS AND PRESSURE RATINGS (American & Metric Units) 2" (50mm) AXIAL MOVEMENT, 1/4" (6mm) LATERAL DEFLECTION

Type & Size	Pipe Size		Face to Face		Axial Spring Rate		Lateral Spring Rate		Thrust [†] @		Rated Pressure		Ship Wt.	
	(in)	(mm)	(in)	(mm)	(lbs/in)	(kg/cm)	(lbs/in)	(kg/cm)	250 psi (lbs)	17 kg/cm ² (kg)	@70°F (psi)	@21°C (kg/cm ²)	(lbs)	(kg)
EW250-2	2	50	21	533	1500	268	2040	364	7070	3207	250	18	22	10
EW250-2 1/2	2 1/2	65	21	533	1500	268	2040	364	7070	3207	250	18	23	10
EW250-3	3	80	21	533	1500	268	2040	364	7070	3207	250	18	24	11
EW250-4	4	100	18	457	1500	268	2040	364	7070	3207	250	18	25	11
EW250-5	5	125	14 1/4	362	1500	268	2040	364	7070	3207	250	18	26	12
EW250-6	6	150	16 1/2	419	1960	350	2450	438	9620	4364	250	18	28	13
EW250-8	8	200	17 1/4	438	2040	364	3980	710	15910	7217	250	18	32	15
EW250-10	10	250	18	457	2500	446	7790	1391	23760	10777	250	18	51	23
EW250-12	12	300	19	483	3530	630	14300	2554	33190	15055	250	18	60	27
EW250-14	14	350	20	508	3700	661	17600	3143	44180	20040	250	18	79	36
EW250-16	16	400	20 1/2	521	4660	832	30650	5473	56750	25741	250	18	107	49

EW may be used for 2" Expansion or 2" Compression from neutral length or any combined 2" from neutral. i.e. (+ 1 1/2, - 1/2) (+ 1, - 1) (+ 1/4, - 13/4) etc. Total movement should never exceed 2".

[†]Lower Thrust Forces in proportion at lower pressures. i.e. 100 psi Force = 100/250 x published Thrust. Anchors must resist Thrust Force plus Spring Force. Spring Force is determined by multiplying the joint Spring Rate by its Thermal Movement (in/mm).

EW's installed in piping systems must be anchored on both sides of the joint. EW's installed in unanchored piping must have control rods.

When using EW products in copper or brass water or steam systems, dielectric unions must be used on each end to prevent leakage from galvanic action.

QTY	SIZE	TAG

QTY	SIZE	TAG