

Class 300 • Union Bonnet* • Rising Stem • Threaded Ends

622E Gate Valve

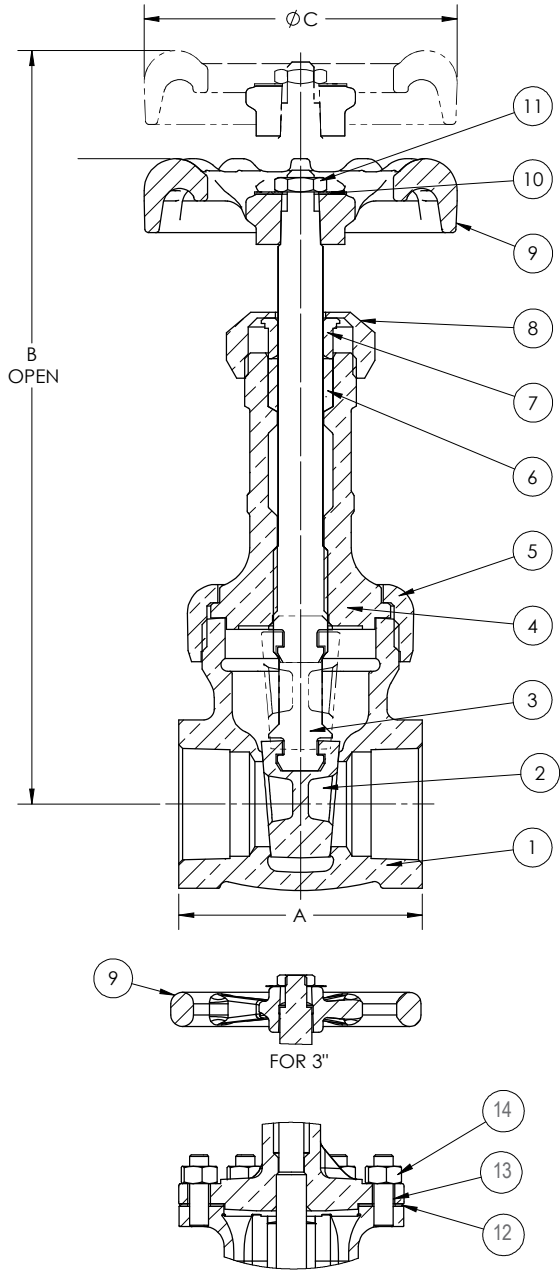

Materials of Construction

No.	Description	Material	ASTM Spec.
1	Body	Bronze	B-61 C92200
2	Disc	Bronze	B-61 C92200
3	Stem	Bronze	B-371 C69400
4	Bonnet	Bronze	B-61 C92200
5	Union Bonnet Ring	Bronze	B-61 C92200
6	Packing	Graphite (Asbestos Free)	
7	Gland	Brass	B-16 H02
8	Packing Nut	Brass	B-16 H02
9	Handwheel	Cast Iron (¼ - 2½") Ductile Iron (3")	
10	ID Plate	Aluminum	
11	Lock Nut	Steel Cadmium	
12	Gasket	Synthetic/Glass Fiber with Nitrile Binder	
13	Stud	Steel Cadmium	A-109 C1144
14	Stud Nut	Mild Steel	A-563 GR A

See page 8 for Pressure-Temperature Ratings.

Industry Standards
MSS SP-80, Type 2

Dimensions and Weights

Inches (millimeters) - Pounds (kilograms)

Valve Size	Dimensions			Wt.
	B	C	A	
¼	4.65	2.25	1.64	0.79
	(118)	(57)	(42)	(0.36)
⅜	4.65	2.25	1.64	0.77
	(118)	(57)	(42)	(0.35)
½	5.37	2.75	2.10	1.28
	(136)	(70)	(53)	(0.58)
¾	6.56	2.75	2.14	1.85
	(167)	(70)	(54)	(0.84)
1	7.60	2.75	2.47	2.99
	(193)	(70)	(63)	(1.36)
1 ¼	9.09	4.00	3.08	4.40
	(231)	(102)	(78)	(2.00)
1 ½	10.24	4.00	3.21	5.46
	(260)	(102)	(82)	(2.48)
2	12.14	4.00	3.47	9.70
	(308)	(102)	(88)	(4.41)
*2 ½	14.65	4.75	4.25	14.83
	(372)	(121)	(108)	(6.74)
*3	16.81	5.50	4.59	22.07
	(427)	(140)	(117)	(10.03)

* 2 ½" and 3" have Bolted Bonnet