

Class 150 • Outside Screw & Yoke • Flexible Wedge Disc

Figure 47

- Gate, Flanged

Figure 47½

- Gate, Butt Weld

Size Range:

- 2 through 24 inches
- (50 - 600 mm)

Pressure Temperature Rating

- Carbon Steel
- ASTM A216 Grade WCB
- 285 psi @ -20°F to 100°F
- (20 bar @ -28°C to 37°C)

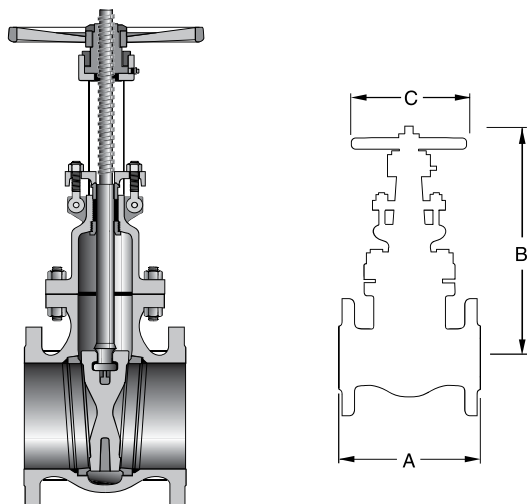

Material of Construction*

Description	Material
Body	ASTM A216 GR.WCB
Seat Ring	ASTM A105N + Alloy 6 Hardfaced
Disc	ASTM A216 GR.WCB + 13Cr Faced
Stem	ASTM A182 GR.F6a
Gasket	304SS + Graphite
Bonnet Bolts	ASTM A193 GR.B7
Bonnet Bolt Nuts	ASTM A194 GR.2H
Bonnet	ASTM A216 GR.WCB
Bonnet Bushing	ASTM A276 Type 410
Spacer Ring	ASTM A276 Type 410
Eye Bolt Pins	ASTM A29 GR.1045
Stem Packing	Braided Graphite & Die formed Graphite Ring
Gland	ASTM A276 Type 410
Gland Flange	ASTM A216 GR.WCB
Gland Eye Bolts	ASTM A193 GR.B7
Eye Bolt Nuts	ASTM A194 GR.2H
Grease Nipple	ASTM A29 GR.1020
Stem Nut	ASTM A439 GR.D-2
Retaining Nut	ASTM A29 GR.1045
Handwheel	ASTM A536 GR.60-40-18
Handwheel Nut	ASTM A29 GR.1045
Screw	ASTM A29 GR.1035
Nameplate	SS304
Screw	SS304

*Standard construction: WCB-Trim 8, other options are available.
Crane recommends the use of manual or powered gear assistance for sizes 10" and larger.

Industry Standards

Steel Valves	ASME B16.34
Face-to-Face/End-to-End	ASME B16.10
Flange Dimensions	ASME B16.5
Weld End	ASME B.16.25
Basic Design	API 600
Testing	API 598

Dimensions and Weights

Inches (millimeters) - pounds (kilograms)

Valves	2	2 ½	3	4	6	8	10	12	14	16 ⁽¹⁾	18 ⁽¹⁾	20 ⁽¹⁾	24 ⁽¹⁾
	(50)	(65)	(80)	(100)	(150)	(200)	(250)	(300)	(350)	(400)	(450)	(500)	(600)
A	7.00	7.50	8.00	9.00	10.50	11.50	13.00	14.00	15.00	16.00	17.00	18.00	20.00
(47)	(178)	(190)	(203)	(229)	(267)	(292)	(330)	(356)	(381)	(406)	(432)	(457)	(508)
A	8.50	9.50	11.12	12.00	15.88	16.50	18.00	19.75	22.50	24.00	26.00	28.00	32.00
(47½)	(216)	(241)	(282)	(305)	(403)	(419)	(457)	(502)	(572)	(610)	(660)	(711)	(813)
B	15.43	17.68	20.24	23.74	30.91	38.39	45.91	54.96	62.91	70.59	77.64	86.73	100.71
(Open)	(392)	(449)	(514)	(603)	(785)	(975)	(1166)	(1396)	(1598)	(1793)	(1972)	(2203)	(2558)
C	7.87	7.87	9.84	9.84	13.78	13.78	15.75	17.72	18.11	18.11	18.11	18.11	21.26
	(200)	(200)	(250)	(250)	(350)	(350)	(400)	(450)	(460)	(460)	(460)	(460)	(540)
Wt.	37.48	46.30	72.75	110.23	185.19	284.40	425.49	604.07	886.26	1117.74	1450.64	1781.34	2877.03
(47)	(17)	(21)	(33)	(50)	(84)	(129)	(193)	(274)	(402)	(507)	(658)	(808)	(1305)
Wt.	33.07	39.68	57.32	90.39	152.12	238.10	343.92	546.75	804.69	1062.63	1294.11	1657.88	3097.49
(47½)	(15)	(18)	(26)	(41)	(69)	(108)	(156)	(248)	(365)	(482)	(587)	(752)	(1405)

(1) Dimensions and weights shown with gear actuator.