

Class 150 • Threaded Bonnet • Rising Stem • Threaded Ends

431 Gate Valve

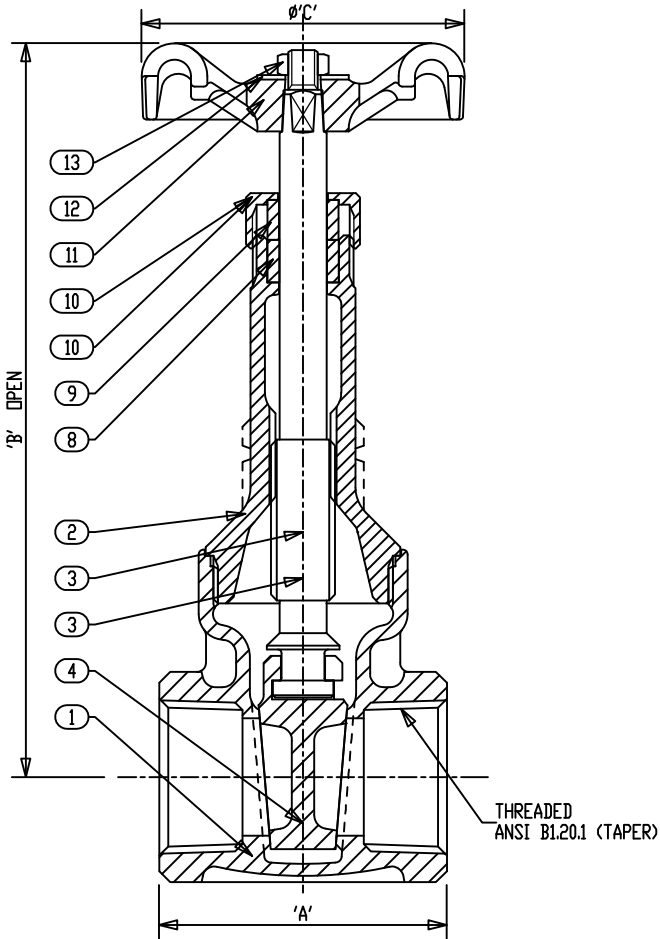

Materials of Construction

No.	Description	Material	ASTM Spec.
1	Body	Bronze	B-62 C83600
2	Bonnet	Bronze	B-62 C83600
3	Stem	Copper Silicon Bronze	B-371 C69400
4	Disc	Bronze	B-62 C83600
8	Packing Ring	Graphite (Asbestos Free)	
9	Gland	Brass	BSEN12164 CW614N
10	Packing Nut	Brass	BSEN12164 CW614N
11	Handwheel	Malleable Iron	A-197 F22000
12	ID Plate	Aluminum	
13	Handwheel Nut	Brass	BSEN12164 CW614N

See page 8 for Pressure-Temperature Ratings.

Industry Standards

MSS SP-80, Type 2

Dimensions and Weights

Inches (millimeters) - Pounds (kilograms)

Valve Size	Dimensions			Wt.
	B	C	A	
1/4	4.96	1.75	1.81	0.7
	(126)	(45)	(46)	(0.32)
3/8	4.96	1.75	1.81	0.7
	(126)	(45)	(46)	(0.32)
1/2	5.07	2.06	1.98	1.0
	(129)	(52)	(51)	(0.46)
3/4	6.25	2.56	2.14	1.6
	(159)	(65)	(55)	(0.72)
1	7.44	2.75	2.46	2.4
	(189)	(70)	(63)	(1.10)
1 1/4	8.62	3.06	2.77	3.3
	(219)	(78)	(71)	(1.50)
1 1/2	9.68	3.62	2.85	4.9
	(246)	(92)	(73)	(2.25)
2	11.85	3.62	3.25	7.0
	(301)	(92)	(83)	(3.20)
2 1/2	14.53	5.28	4.25	12.8
	(369)	(134)	(108)	(5.80)
3	16.39	5.28	4.59	18.8
	(416)	(134)	(117)	(8.52)