

Class 300 • Threaded Cap • Y-Pattern • All Iron • Threaded

346 1/2 Check Valve

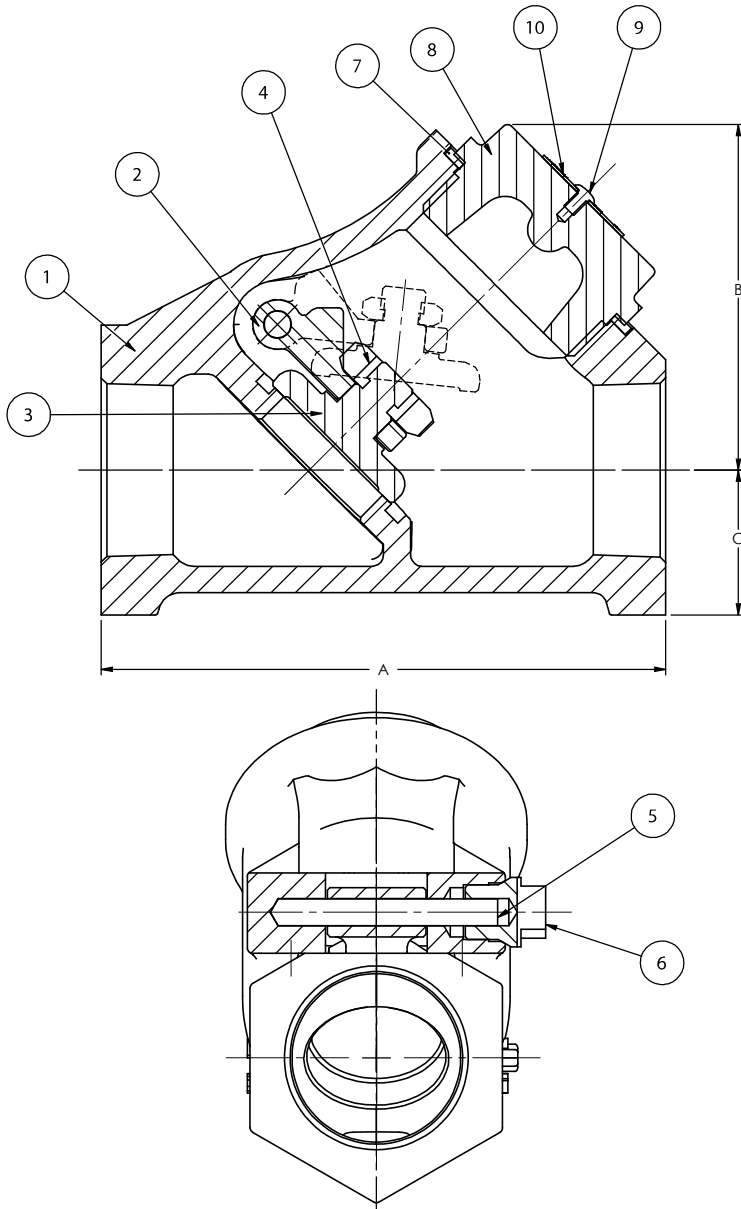

Temperature Valve Ratings		Working Pressures, Non-shock, PSI	
°F	°C	PSI	kPa
-20 to 100	-30 to 37	640	4412
200	93	600	4136
300	149	565	3895
400	205	525	3619
500	260	495	3412
600	315	465	3206
650	343	450	3102

Materials of Construction

No.	Description	Material	ASTM
1	Body	Ductile Iron	A536, 65-45-12
2	Hinge	Ductile Iron	A536, 65-45-12
3	Disc	Ductile Iron	A536, 65-45-12
4	Nut	Steel	A194 2H
5	Hinge Pin	Stainless Steel	AISI 410
6	Plug	Stainless Steel	AISI 304
7	Gasket	Aramid Fiber Blend with Nitrile Binder	
8	Bonnet Cap	Ductile Iron	A536, 65-45-12
9	Rivet	Steel	
10	ID Tag	Anodized Aluminum B&S Gauge #24	

Industry Standards

MSS SP-71

ASME B1.20.1

Dimensions and Weights

Inches (millimeters) - Pounds (kilograms)

Valve Size	Dimensions			WT
	A	B	C	
1/2	2.75	1.69	1.06	1.34
	(70)	(43)	(27)	(.61)
3/4	3.27	1.90	1.06	1.67
	(83)	(48)	(27)	(.76)
1	4.06	2.45	1.06	2.50
	(103)	(62)	(27)	(1.11)
1 1/4	4.75	2.85	1.30	3.52
	(120)	(73)	(32)	(1.60)
1 1/2	5.40	3.29	1.40	5.42
	(137)	(84)	(36)	(2.46)
2	6.62	4.28	1.70	9.19
	(168)	(109)	(43)	(4.17)