

Cast Steel: Gates/Globes/Checks

Milwaukee Valve Company

WCB Body/Bonnet/Cap/API 8 Trim

Features and Benefits

Gates

- Flexible Wedge for improved seating
- 2 bolt adjustable stem packing arrangement for longer packing life
- Stems have a grounded finish for improved packing seal
- Outside Screw and Yoke rising stem design

Globes

- Rotating seat disc for improved seating
- Outside Screw and Yoke rising stem design
- 2 bolt adjustable stem packing arrangement for longer packing life

Swing Checks

- Horizontal design
- Pinned rotating disc for improved sealing

Gate/Globe/Swing Checks

- Seat faces lapped for improved sealing
- Seats rings are sealed-welded for stable shut-off
- API 8 trim standard on Gate/Globe/Checks
- Materials to ASTM standards
- Heat codes and MTR's provided for traceability of each valve

Product Range

- ASME Class 150/300/600 Flanged and Butt-Weld Connections
- Size Range: 2"-24", Consult Factory for larger sizes

Operators Available

- Handwheel and Bevel Gear Operators available
- Electric Actuation available for Gates

Materials of Construction

- Body/Bonnet/Cap: ASTM A216 Gr WCB Cast Steel
- Trim: API 8 standard
- Stem: ASTM A182 F6a (410 Gr SS) for Gates/Globes
- Seats: A105-Cr-Co Hard faced seats and Seal Welded
- Packing: Multiple Graphite rings for Gates/Globes
- Body Gaskets: Graphite/Stainless Steel

Specifications and Standards

- Design: Wall Thickness & Trim API 600/ASME B16.34
- Connections: Flanges to ASME B16.5/Butt-weld to ASME 16.25
- End to End Dimensions: ASME B16.10
- Testing and Inspection: API 598, RP 591
- Pressure and Temperature: ASME B16.34
- Operating Temperature: -20 to 800° F
- By-Passes and Drains: MSS SP-45



The information presented on this sheet is correct at time of publication. Milwaukee/Hammond Valve reserves the right to change design and/or materials without notice. For our Installation, Operation and Maintenance Manual and the most current product information go to www.milwaukeevalve.com or www.hammondvalve.com.
⚠ State of California Prop 65 **WARNING:** Cancer and Reproductive Harm. For more information visit www.p65warnings.ca.gov.

1550CB2 FLANGED ENDS 1552CB2 BUTT-WELD ENDS GATE CLASS 150 14''-24''

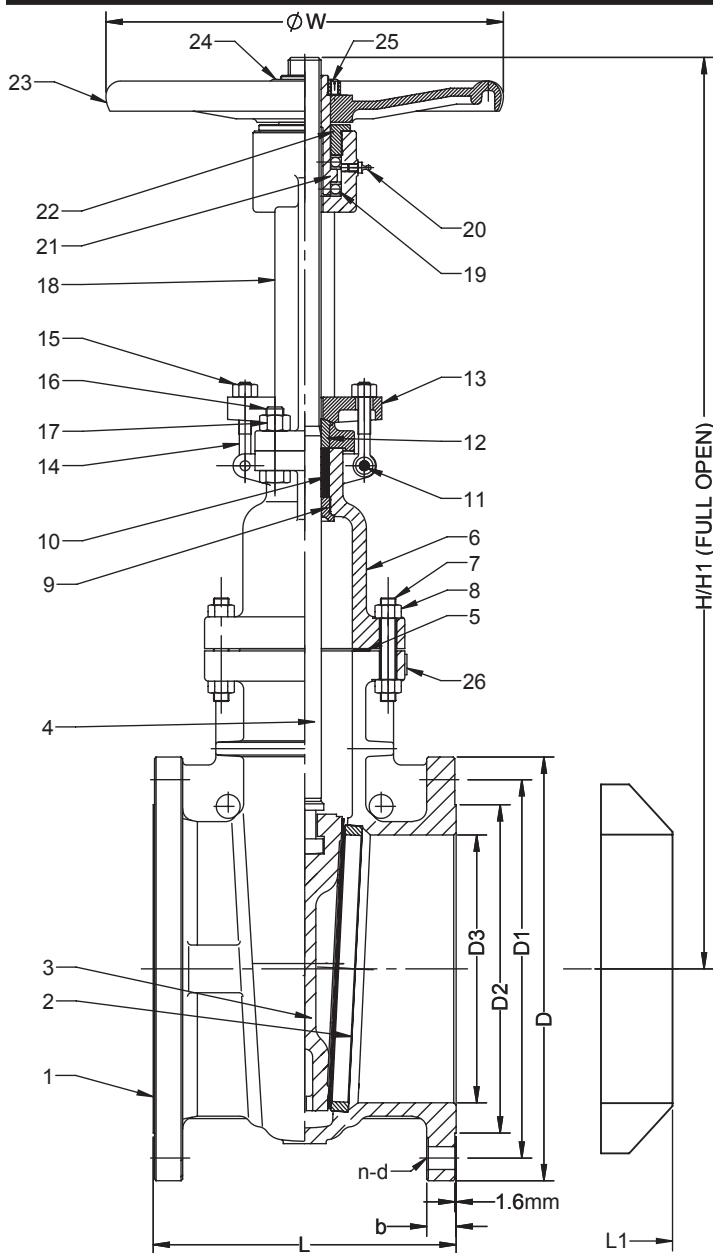

SPECIFICATIONS		
DESIGN: API 600 12 Edition, ASME B 16.34		
PRESSURE-TEMP RATINGS: ASME B 16.34		
CONNECTIONS: ASME B 16.5, B 16.25		
FACE TO FACE : ASME B 16.10		
TEST & INSPECTION: API 598 RP 591		
MATERIAL LIST		
ITEM	PART NAME	MATERIAL
1	BODY	ASTM A216 WCB
2	SEAT RING	A105+Co-Cr-W
3	WEDGE	ASTM A216 WCB+13Cr HF
4	STEM	ASTM A182 F6a
5	GASKET	GRAPHITE+SS CORE
6	BONNET	ASTM A216 WCB
7	STUD BODY/BONNET	A193 B7
8	NUT BODY/BONNET	A194 2H
9	BACKSEAT BUSHING	A276 TYPE 420
10	PACKING	GRAPHITE
11	GLAND EYEBOLT PIN	CARBON STEEL
12	GLAND	A276 420
13	GLAND FLANGE	ASTM A216 WCB
14	GLAND EYEBOLT	CARBON STEEL
15	GLAND EYEBOLT NUT	CARBON STEEL
16	YOKE BOLT	CARBON STEEL
17	YOKE NUT	CARBON STEEL
18	YOKE	ASTM A216 WCB
19	BEARING	BEARING STEEL
20	GREASE FITTING	BRASS
21	YOKE BUSHING NUT	A493 TYPE D2
22	YOKE BUSHING	CARBON STEEL
23	HANDWHEEL	ASTM A536
24	HANDWHEEL NUT	CARBON STEEL
25	SET SCREW	CARBON STEEL
26	NAMEPLATE	304 SS

SIZE		L FACE TO FACE	L1 BUTT WELD	D DIA	D1 BOLT CIRCLE	D2 RAISED FACE DIA	D3 DIA	b THICKNESS	n NUMBER OF HOLES	d HOLE DIA	H CLOSED	H1 FULL OPEN	W HANDWHEEL	C _v
14"	IN	15.00	22.52	20.98	18.75	16.26	13.27	1.38	12	1.14	45.08	59.25	19.69	16275
	MM	381	572	533	476	413	337	35		29	1145	1505	500	
16"	IN	16.00	24.02	23.50	21.25	18.50	15.24	1.44	16	1.14	50.83	67.09	23.62	21560
	MM	406	610	597	540	470	387	37		29	1291	1704	600	
18"	IN	17.00	25.98	25.00	22.75	20.98	17.24	1.56	16	1.26	56.14	74.17	25.59	28720
	MM	432	660	635	578	533	438	40		32	1426	1884	650	
20"	IN	18.00	27.99	27.52	25.00	22.99	19.25	1.69	20	1.26	61.97	82.20	27.56	35760
	MM	457	711	699	635	584	489	43		32	1574	2088	700	
24"	IN	20.00	32.01	32.01	29.50	27.24	23.27	1.88	20	1.38	72.87	97.17	31.50	52165
	MM	508	813	813	749	692	591	48		35	1851	2468	800	

The information presented on this sheet is correct at time of publication. Milwaukee/Hammond Valve reserves the right to change design and/or materials without notice. For our Installation, Operation and Maintenance Manual and the most current product information go to www.milwaukeevalve.com or www.hammondvalve.com.
 ⚠ State of California Prop 65 **WARNING:** Cancer and Reproductive Harm. For more information visit www.p65warnings.ca.gov.

